

*Setting the sights specifically on the audio frequency band*  
**How to take successful measures  
 against noise**

**Introduction**

The frequencies whose noise is restricted by laws and regulations start at 150 kHz for conducted noise and at 30 MHz for radiated noise. This means that the audio band with its upper limit of 20 kHz is not subject to any laws and regulations, but the approach taken to noise is still the same.

Specific examples of the kinds of noise interference we experience in our everyday lives include the noise we hear when we listen to an AM radio or talk on the telephone, the interference that affects the pictures on our display screens and TV screens and the interference that prevents communication at the higher speeds inherent to ISDN and ADSL. Even in the audio field, very faint playback sound must be adversely affected by noise although what is actually is not satisfactorily understood. In this paper, the author will focus on noise in the audio frequency band, and he will attempt to define what this noise is and consider what measures can be taken to deal with it effectively.

● **Do personal computers adversely affect the sound we hear or not?**

In the author's case, the electrical wires in the home originating at the circuit breakers are connected through the adjoining rooms and end up in his room. There is a desktop computer running in an adjoining room, its power consumption is always a high 100W or so, and the switching frequency is a low 100 kHz or less. One concern of the author's has been that the sound of audio equipment is being adversely affected in some way or other. In fact, it is this very concern that motivated him to write this paper.

● **Detecting (radiated) noise**

In the world of audio, noise is often treated from a sense-based perspective. In this paper, however, the author would like to discuss noise in terms of some concrete data that can actually be verified to the extent possible. To this end, the author used a battery-operated AM radio (the ICF-SW77 made by Sony, but other models would be equally acceptable) as the main detectors of noise because they are easy to obtain and they are very good at detecting noise.

● **Recording the signals**

To record the signals and convert them into digital data, the author used a personal computer and a Sound

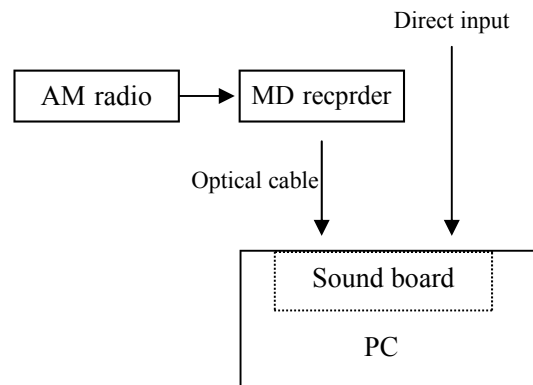

Blaster Live Pro sound board. In cases where the signals could not be directly connected to the sound board, the author first recorded them using an MD recorder and transferred the recorder's output to the sound board through an optical cable.

● **Spectrum analysis software**

The author used the WaveSpectra V1.30 software which can be downloaded as freeware <http://www.ne.jp/asahi/fa/efu/soft/ws/ws.html> One condition--that the frequencies involved be 20 kHz or below--must be met when a combination of a sound board with the spectrum analysis software is used, but this combination turned out to be a powerful tool for analyzing frequency characteristics and signal levels.

● **Signal levels and frequencies**

This is a good point at which to take an overall look at the frequencies and signal levels of noise. Sound is susceptible to noise when its signal levels are low and when the frequencies of its signals are close to the noise frequency. Broadly speaking, audio-related signal levels are in the order of:

- Microvolts ( $\mu$ V) for AM broadcasts, etc.
- Millivolts (mV) for analog record outputs
- Volts (V) for CD outputs and line signals.

Compared with the CD format, analog record outputs are a thousand times more susceptible to noise, and AM broadcasts are a thousand times more susceptible than analog record outputs. The various signal levels and frequencies found in our homes are provided on the next page.

The following cause and effect relationships apply to noise: the higher the signal level, the more easily it can become the “offender” and the less it can become the “victim” while, conversely, the lower the signal level, the less it can become the “offender” and the more it can become the “victim.” In reality, both signals with high levels and signals with very weak levels often coexist inside the same electronic product, and audio equipment is a typical example of such a product.

Furthermore, the products we can identify as generators of noise when we come close enough to them include:

- Inverter fluorescent lights
- Digital displays of CD player, fan heater, etc.
- ADSL modem and hub

The air purifier generates its negative ions by high-voltage discharge. The voltage-boosting circuit used in generating the ions has a low operating frequency, and this is the principal source of noise.

● **Checking out noise sources present in the authors’ room using an AM radio**

Putting aside desktop computers which are in a class of their own, the author found that the following products are major sources of radiated noise:

- Air purifier that generate negative ions
- AC power cables of massage chair
- Combustion parts of fan heater

Among these products, the air purifier is by far the biggest generators of radiated noise while the other products generate more or less the same level. Fur-

● **Noise from the AC power cable of a massage chair and the effects of the Quiet Line parallel-type noise filter**

Let us now set about detecting the noise radiating from the AC power cable of a massage chair. The



**Air purifier that generates negative ions found to be a major source of radiated noise**



**Radiated noise from power cable of a massage chair (power ON and power OFF)**

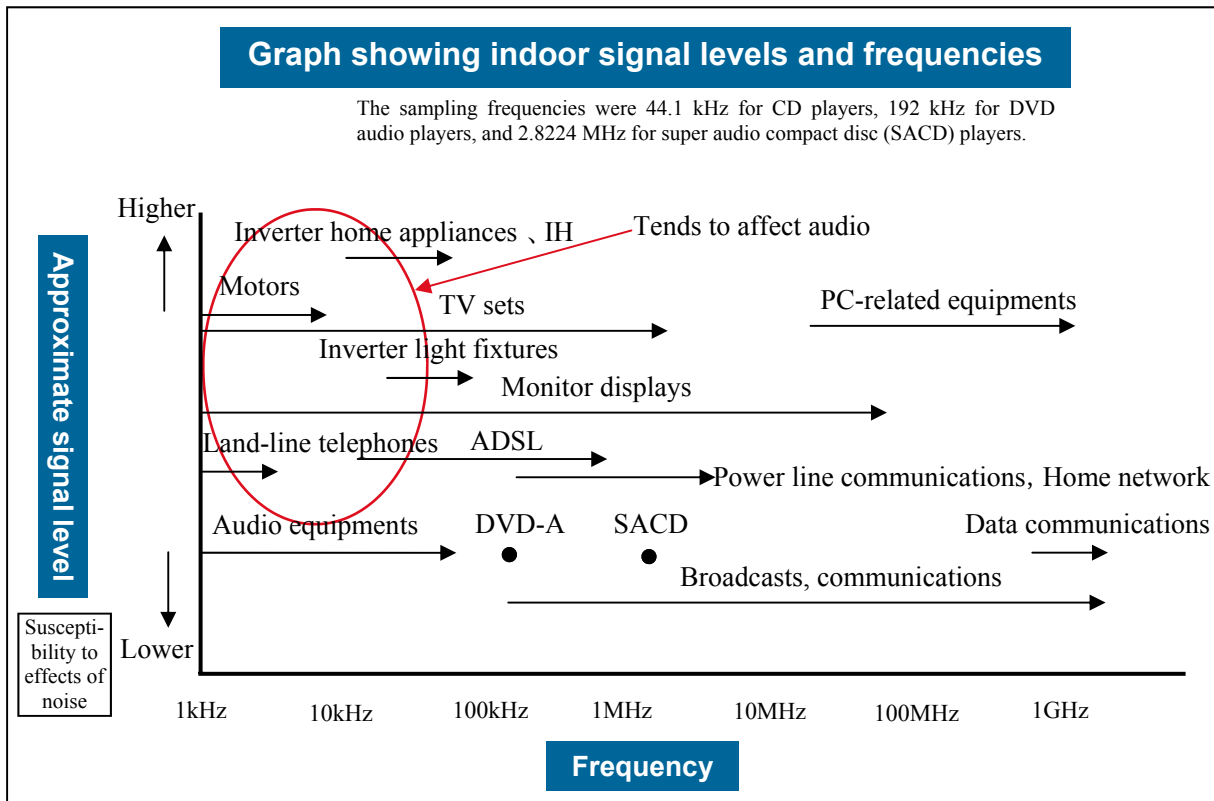



Parallel-type noise filter Quiet Line

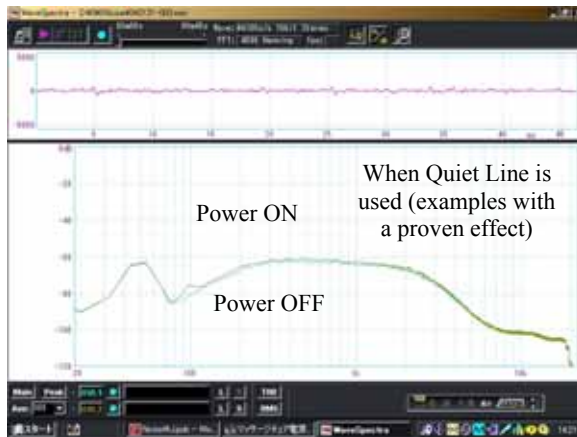

Radiated noise of massage chair power cable (when Quiet Line was used)

following results were obtained when the author brought the ferrite antenna of his AM radio near the AC power cable and measured the radiated noise which was detected when the power of the massage chair was on and when it was off.

When the power of the massage chair was on, the noise detected increased by up to 20 dB or so in the 100 Hz to 10 kHz frequency range. This was due to the fact that a switching power supply is incorporated inside the massage chair.

Next, the author plugged the parallel-type Quiet Line noise filter available from Audio Prism (<http://www.audioprism.com/>) into an empty power outlet, and measured the effect it had on the noise.

If we compare the results with what is shown in the graph on the previous page, it is clear that almost all the noise generated by the massage chair was suppressed through the use of Quiet Line. Conversely, however, when the noise was measured at an inverter fluorescent floor lamp, it actually increased. It is therefore not possible to say that this filter has a stable and sure-fire effect in all situations.

● Rectification circuit diode noise

It is common knowledge in the world of audio that the diodes used for 50/60 Hz rectification circuits could affect the sound.

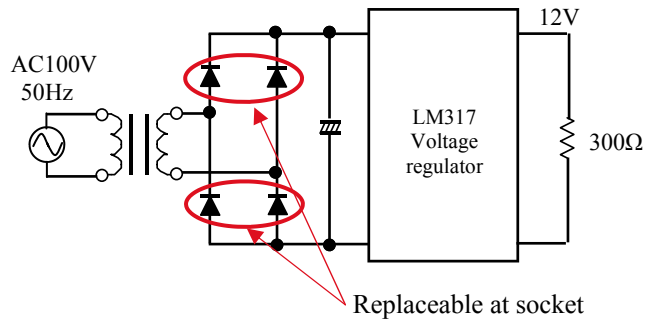

Rectification noise comparison circuit



Detection of diode noise

The power supply shown in the photo employs a 12V output constant-voltage circuit which is designed to enable the bridge rectifier diode to be replaced at the socket, and since its load is 300 ohms, its output current is 40mA or so. The author brought the antenna part of the ICF-SW77 AM receiver as close to the transformer as possible and secured it at a position where the noise was highest. While taking care not to change the relative positions of the receiver and transformer, he switched over the diode.

The following three diodes were used for the purposes of this comparison:

- For general rectification, DBF10G, 1A/600A
- 200V FRD FCF/FRF10A20, 5Ax2/200V
- 200V SBD FCH/FRH10A20, 5Ax2/200V

The results are presented on the next page. In the case of the diode used for general rectification, the rectification noise was of a higher order compared with the fast recovery diodes, and a loud buzzing noise was heard coming from the AM receiver.

The rectification noise of diodes does not pose any problems at all in the actual circuits. In this context, a transformer with bare windings and no magnetic shielding was used to emit noise (bring about changes in the magnetic field) to the maximum extent possible, and the very minor changes in the magnetic field were picked up by the loop antenna housed inside the high-sensitivity AM radio. This noise was suppressed simply by moving the antenna only a short distance away from the transformer. Even with the diode used for general rectification, this noise is suppressed by adding a ceramic capacitor with a capacitance of 1,000pF

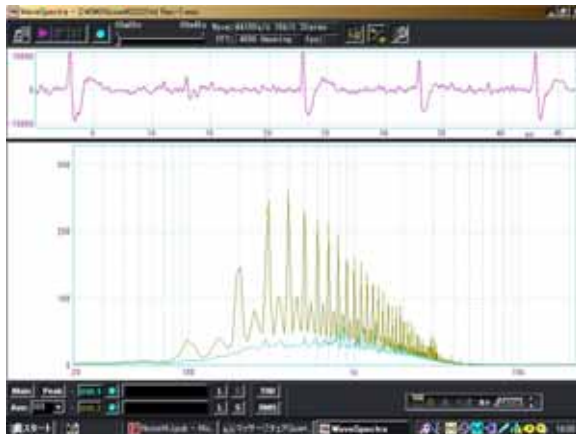

**Rectification noise picked up by AM radio**  
Diode for general rectification

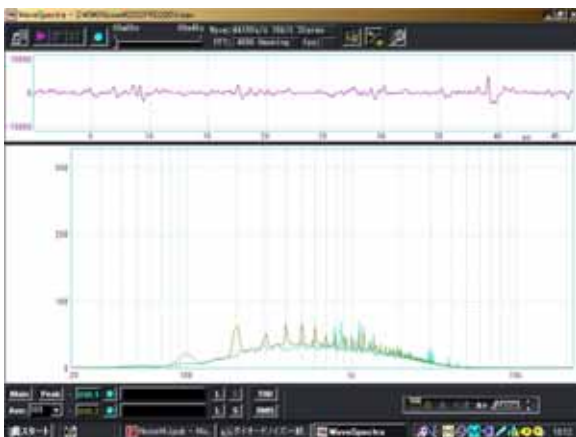

**Rectification noise picked up by AM radio**  
200V FRD (FCF/FRF10A20)

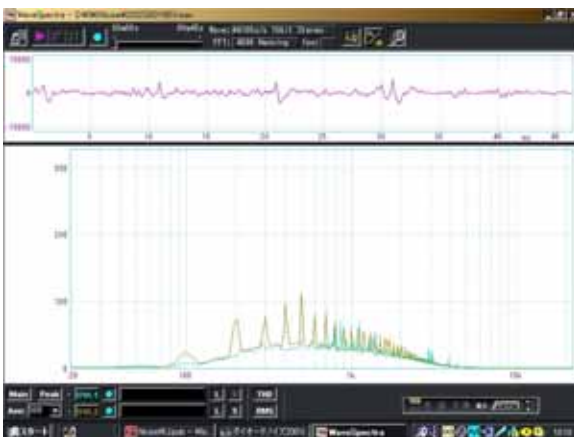

**Rectification noise picked up by AM radio**  
200V SBD (FCH/FRH10A20)

or so in parallel. However, ringing will occur unless damping is accomplished effectively, and there is the possibility that high-frequency noise in the frequency range from MHz to several dozen MHz will be increased. From this standpoint, the use of a fast recovery diode which has an extremely low noise source energy level to begin with is a wise choice in terms of sharply reducing the noise source itself. By way of precaution, the author measured whether the rectifica-

tion noise was affecting the constant-voltage output using an oscilloscope but, as he expected, he was not able to perceive any disparity due to differences in the diodes.

● **Conducted noise (1 of 2): Noise entering the AC power line of an air purifier**

The diode rectification noise described above is a type of noise which is generated from the electromagnetic waves released into the atmosphere, and it is referred to as radiated noise. The other category of noise is conducted noise which, as its name implies, is conducted or carried through wires and cables. Using some simple tools, the author checked out

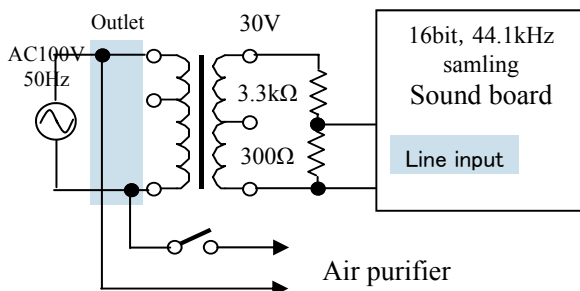

**Measurement of AC line conducted noise emanating from air purifier**

whether his air purifier that generates negative ions--a unit which was radiating some high-level noise--was also passing conducted noise to the power line. Here, too, the targeted frequency was the audio band of 20 kHz and below.

After reducing the AC power line voltage to 30V using a power transformer, the author further reduced the voltage to about 1V using a resistance voltage divider, and supplied the voltage to the sound board. The 50/60 Hz power transformer featured characteristics enabling it to be used as a line transformer across the audio band.

The results yielded by observing the AC line noise with the air purifier operating in the high-speed mode (the unit's highest operational setting) and with the air purifier off are presented on the next page.

As can be seen from the waveform shown at the top of the spectrum analysis, the AC line voltage may be sinusoidal in nature but its peaks and dips are flattened out, and it contains a large number of lower-order harmonic components. However, as there is no difference between when the air purifier is on and when it is off, it is not possible to identify any noticeable suppression of the conducted noise from the air purifier. The radiated noise is intense, and the rotational noise of the fan is tremendously high at the unit's highest operational setting. Even in this state, the power consumption is slightly over 30W and a low 3W during steady-state operation with ion generation so it can be assumed that the original noise is also low.

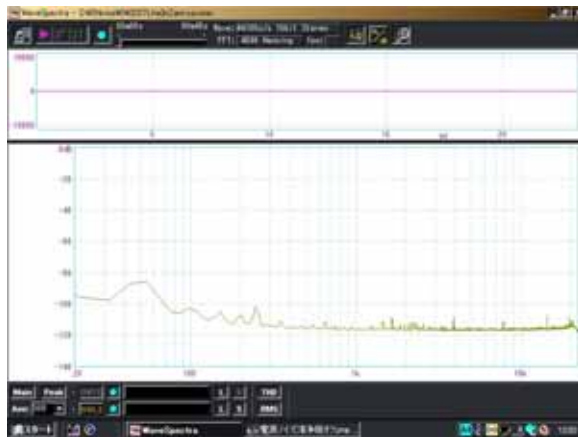

Line input residual noise of sound card

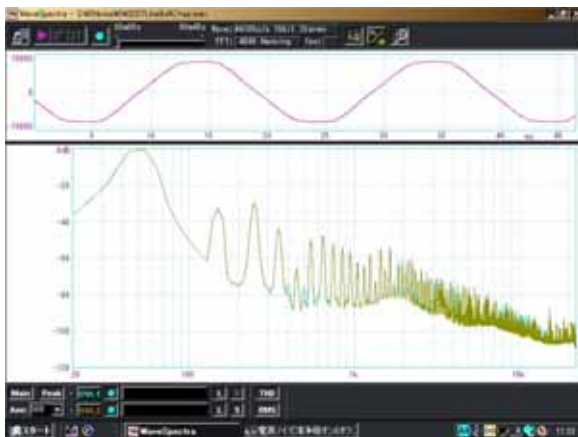

AC line noise generated by air purifier ON/OFF (ON and OFF noise levels superimposed)

● **Conducted noise (2 of 2): Conducted noise entering the AC power line from personal computers**

The author checked out how the conducted noise was being carried through the indoor wiring from the desktop computers which were running. In the example presented above, the signals were captured directly by the sound board in the personal computer. Here, however, the measurement point was at a distance from the personal computer so the signals were first recorded on a battery-powered MD recorder and then transferred to the personal computer.

Although normally only one personal computer would be in use at any point in time, the author chose to have two computers running in order to increase the volume of noise. The two computers, PC1 and PC2, were run while subjecting their CPUs to the highest possible load conditions. The power consumption which the author actually measured was 135W or so for each computer.

The personal computers were running at the far end of the indoor wiring, and their power outlet was designated as A. Upstream back along the indoor wiring were power outlets B and D and also E, after which came the circuit breakers. Outlets A, B and D were

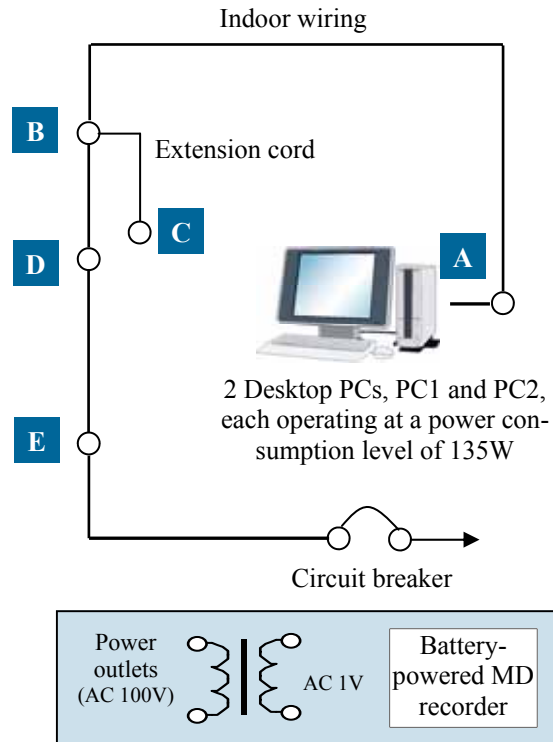

**Measurement of conducted noise entering AC line from PCs**

located in the author's room (with a floor area of 10 tatami mats), and outlet E was in an adjoining room. An extension cord was plugged into outlet E, and its end was designated at C. (The power for the audio equipment was taken from outlets B and C.) Apart from the two personal computers running off the power from outlet A, no devices were connected to any other outlets.

The data obtained by comparing the conducted noise from 1 kHz to 20 kHz at each of these points is presented on the following page.

When these results are compared, the noise conducted along the AC power line diminishes as it moves away from the noise source, and at point E in the adjoining room its effect is virtually negligible. The fact that the indoor wiring and cables act as filters is believed to be responsible for this.

Based on these findings, it appears safe to say that the conducted noise at point B (the outlet to which the audio equipments are connected) and point C in the author's room is nothing to be concerned about even when the personal computers are running at point E in the adjoining room. In actual fact, the author ran the personal computers at point E and measured the conducted noise at point B, but he could detect no significant difference between while the computers were running and while their power was shut down.

At this point, the author would like to go back to basics to understand what noise is and consider what measures can be taken to deal with it.

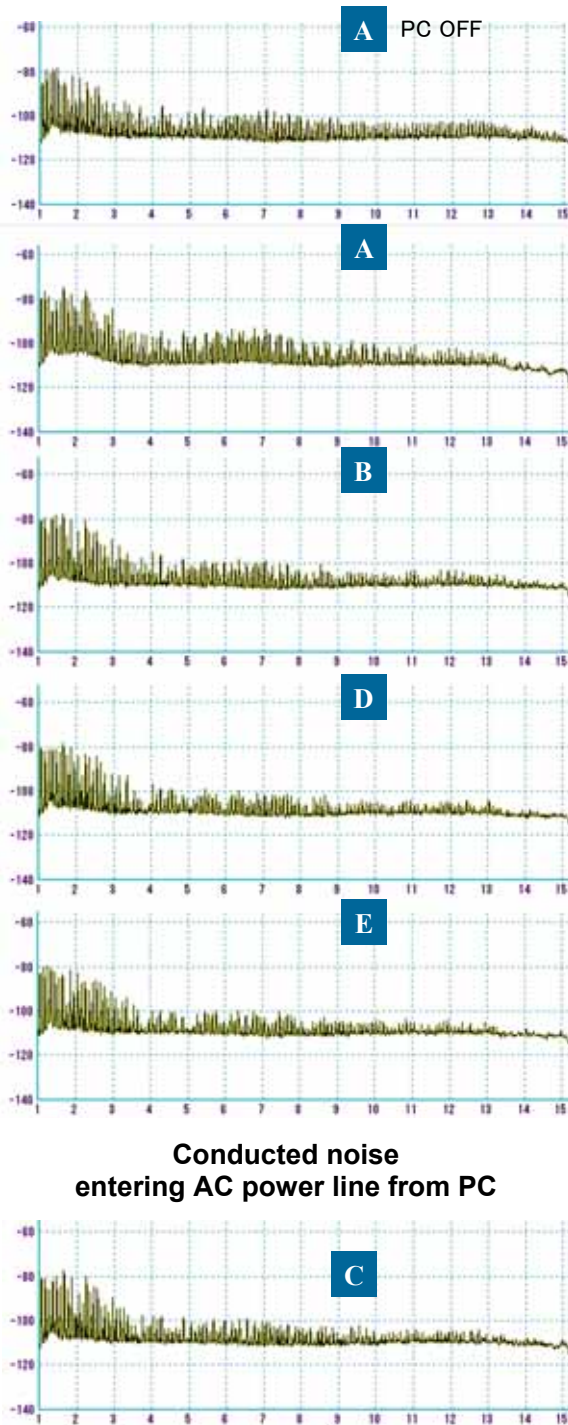

**Conducted noise entering AC power line from PC**

**Effects exerted by extension cord (extended from point B)**

## ●EMC, EMI, EMS

Earlier on, the author discussed noise problems in terms of the “offender” and “victim.” The term EMC (electromagnetic compatibility) is used to cover both of these aspects. Electromagnetic compatibility implies that a product will:

1. Not induce electromagnetic interference in other systems.
2. Not receive electromagnetic interference from other systems.
3. Not induce electromagnetic interference in itself.

EMC, EMI (electromagnetic interference) and EMS (electromagnetic susceptibility) stand in the following relationship to one another:

$$\text{EMC} = \text{EMI} + \text{EMS}$$

Electronic equipment takes measures to suppress noise on two fronts: noise generation and noise infiltration.

A number of international standards have been established by various bodies, and these standards include:

- VCCI in Japan
- FCC in the USA
- EN55022 in the EC
- VDE0878 in Germany
- BS6527 in the UK

The electronic equipment used in commercial and business applications must satisfy these standards. The lowest limit frequency of the conducted noise targeted by these regulations is 150 kHz. This frequency of 150 kHz is also the lower-limit frequency of the LW (long wave) band which is used for shipping and aircraft communications. That is to say, that the purpose of these noise restrictions is to prevent interference with broadcasts, communications, and data transmission. Conversely, it can be said that nobody is concerned with noise in frequencies lower than 150 kHz. Incidentally, the lowest frequency of radiation interference which is subject to restrictions is 30 MHz.

## ●Common mode and normal mode

Two signal lines are normally needed for electrical signals to be transmitted. The signals are provided as changes in the potential of one line using the other line as a reference. Normal mode noise is what is superimposed onto this potential. Common mode noise is another form of noise which changes the signals of both signal lines. Different countermeasures are employed depending on whether normal mode

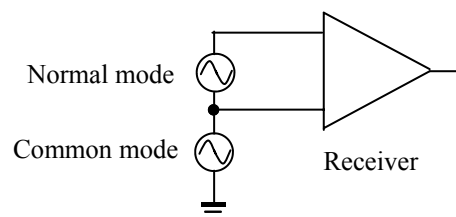

**Normal mode and common mode noise**

noise or common mode noise or both normal mode noise and common mode noise are involved. Normal mode noise is hard to differentiate from the original signals. However, since it has a different frequency band, the actual design of the products usually ensures that it will not pass through the receiver. For this reason, it is common mode noise which is considered to be power supply noise and otherwise considered problematic. This way of thinking may be accurate enough as far as digital data is concerned, but when it comes to analog audio signals, the author believes that normal mode noise is more significant.

**●Low-frequency noise and high-frequency noise**

When noise is discussed today, what is mainly talked about are the frequencies from 100 kHz to 100 MHz or so. This is the case because it would be acceptable if it were not possible to communicate because errors have occurred in data communications or if the communication takes much longer to complete because of errors. On the other hand, the upper limit of the frequencies that affect audio is 100 kHz at most. For the sake of convenience, the author will use the figure of 100 kHz as a dividing line as it were so that frequencies higher than 100 kHz will be referred to as “high frequencies” and frequencies lower than 100 kHz as “low frequencies.”

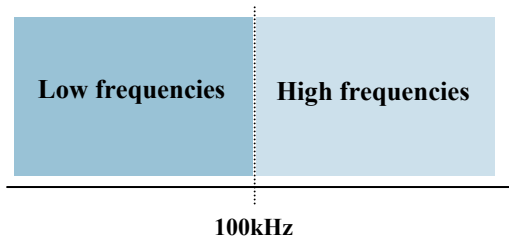

**●Noise (EMC) countermeasures**

According to the Basics of EMC Countermeasures from TDK Corporation, EMC countermeasures are grouped together as shown below.

What the author did was observe the radiated noise of diodes. Use of fast recovery diodes with minimal noise translates into the selection of components which do not emit noise as part of the components. Also, immunity from the effects of radiated noise can be provided by shielding. Another effective EMC countermeasure is to separate the power supplies from the signal systems.

Conducted noise that has entered the power supplies can be attenuated using noise filters which are inserted into the AC power lines.

When all the countermeasures for everything concerned are combined, it is possible to put together electronic products that exhibit excellent EMC.

This is a good point at which to take a look at the noise filters which attenuate the conducted noise in power lines and signal lines.

**●AC power line noise filters**

The noise filters which are incorporated into table taps or provided separately are serial-parallel types with the typical configuration shown below.

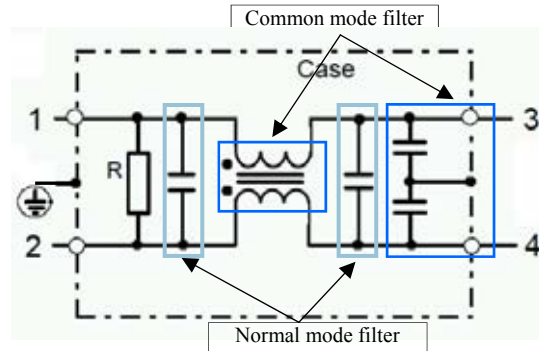

Typical AC line filter

**EMC countermeasures**

<b>Electrical, electronic components</b>	Selection	No noise output or received
	Filtering	On-board: Signal lines On-board: DC power supply lines AC power supply lines Harnesses, cables
<b>Circuit boards, wiring</b>	Patterning	Separation between power supply and signal
<b>Chassis</b>		Separation between digital and analog
<b>Cables</b>	Grounding	Thick, short and twisted 1-point grounding Multi-point grounding
	Shielding	Shielding of circuits, components Shielding of harnesses, cables Shielding of each function block

Filters are comprised of common mode filters and normal mode filters. Filters with added varistors that work in the common mode to afford protection from lightning surges are often used in personal computers. In these kinds of AC line filters, the normal noise filter portion is comprised of a serial type, and the common mode filter portion is comprised of a serial type and parallel type. The whole unit is inserted in series into the AC line so it can be called a serial type. An example of how effective one of these filters can be in attenuating noise is provided in the graph below. This graph shows the degree of attenuation versus the frequency for both the common mode and normal mode. Although the filter in this example is designed for use with low-current single-phase AC power lines, other kinds of filters that, for instance, handle higher current levels or are designed for use with 3-phase AC power lines are also available on the market.

ZCB2203-M

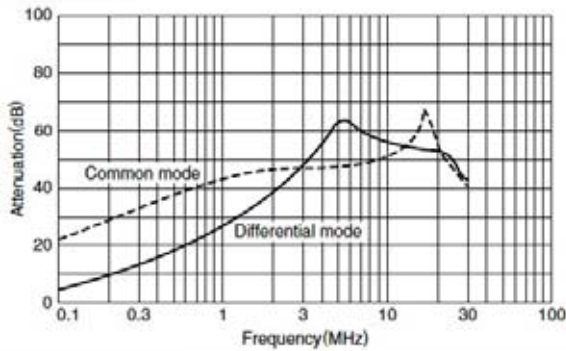

**TDK ZCB2203-M and its noise attenuation characteristics**



**TDK ZCB2203-M**

The fact that the bottom limit of the attenuation characteristics frequency axis is 100 kHz shows that this particular noise filter is for high-frequency uses. At 100 kHz, the filter has hardly any effect on normal mode (differential mode) noise. However, it has the ability to attenuate common mode noise by 20 dB, that is to say, reduce it to one-tenth. At frequencies below 10 kHz, it cannot be expected to have any effect in suppressing noise in audio applications where the frequencies below 10 kHz are most commonly used.

**● Noise filters dedicated to the common mode**

This common mode filter is attached to the cable of a

memory card reader. They suppress noise by providing the two signal lines with impedance. The characteristics of a typical clamp-on filter are as follows.



**Card reader with clamp-on filter**

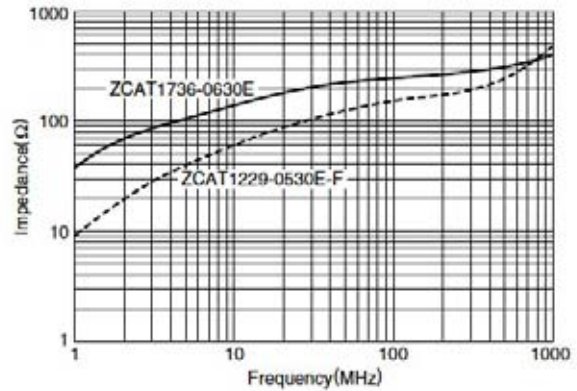

**TDK ZCAT Impedance versus frequency characteristics**

As is clear from the fact that 1MHz is the bottom limit of the frequency axis, these filters are for high-frequency uses.

**● (Genuine) parallel-type noise filters**

It may be odd to use the word “genuine” in this context, but there are parallel-type noise filters that deal with normal mode and even low-frequency noise. One example is Quiet Line which was used in the measurements described earlier. Its manufacturer instructs that it be plugged into an empty AC outlet near the noise source for use.

If this filter is used, the radiated noise emanating from the power cable can be observed to diminish in

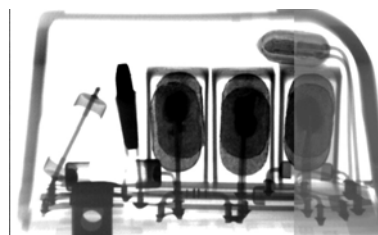

**Internal X-ray photo of Quiet Line**

an AM radio. The author's experiments showed that it was effective for a massage chair but that, conversely, the noise actually increased when inverter fluorescent lights were present.

An internal X-ray photo of the Quiet Line shows that this filter is composed of resistors and a capacitor. The other visible components are believed to be ones related to the LED which lights when the unit works as a noise filter.

This kind of parallel filter is not very common, but it is worth using it if it has a definite effect under particular conditions.

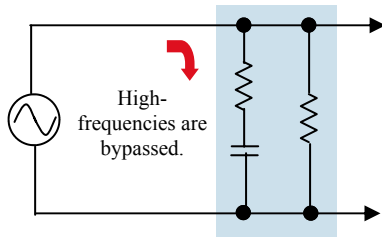

● **AC inlet filters**

These filters are integrated into a single unit with the AC line receptacle. Their characteristics are as shown in the graph below.



**TDK ZUG-12A**

ZUG2203-12A/ZUG2206-12A

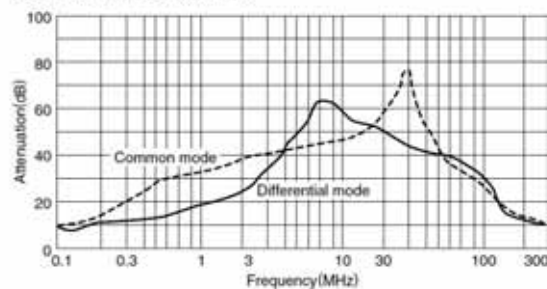

**Characteristics of AC inlet filter**

These high-frequency filters also target frequencies above 100 kHz.

This type of filter is often used for measuring devices and desktop computers. The power switch is located after the filter to prevent make/break surges from being discharged outside and also to block external noise at its point of entry. In addition, the length of the wiring from the inlet to the power board is made as short as possible to suppress noise entering inside the equipment. In this sense, it makes sense that the AC input terminals and filter are integrated as a single unit. Even when this kind of inlet filter is positioned

at the entrance to the equipment and a noise filter is also provided in the power supply unit, they are not redundant: There is value in having each filter in place.

The author has taken a look at the noise filters which are found around us. As is clear, almost all noise filters deal with high frequencies above 100 kHz. Consequently, they cannot be expected to have any effect on the sound heard from audio equipment.

**Noise interfering with low-frequency analog signals and how to deal with it**

The title of this subsection may come across as somewhat grandiose, but the main point of the subsection is to discuss whether the noise has any effect on sound. Sound is audio.

The author would definitely like to point out here that he is using the term "audio" not in the context of radio-cassette combinations, mini components and other mass-market audio products but to refer to the kind of high-end audio equipment designed to be used by audiophiles.

Components equipped with a graphic equalizer are not affected by digital noise. The signals and noise constitute a perfect whole and are inseparable, and the effects of very faint extraneous noise can be ignored. Also, if a level of 0 dB (the highest level which can be played back) appears frequently in the source to be played back, the very faint sounds which contain the noise emanated concurrently cannot be picked up by our ears. In situations like this, there is no sense in discussing noise.

● **Analog signals and digital signals**

Earlier on, the author mentioned that signal levels are in the order of:

- Microvolts ( $\mu$ V) for AM broadcasts, etc.
- Millivolts (mV) for analog record outputs
- Volts (V) for CD outputs and line signals.

These are nominal voltages, and if the range is 60 dB or 80 dB, the lowest possible values would be one-thousandth or one ten-thousandth of these levels. One-thousandth of one volt is 1mV, and one ten-thousandth of one volt is 100 $\mu$ V. This means that when it comes to playback signals, even noise below 1mV poses problems. This is the world of analog signals.

In contrast, even with the capacity of 480 Mbit/s specified with USB 2.0 for digital signals, it only

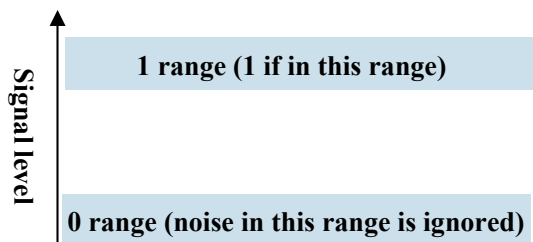

**Digital signals are resistant to noise**

means that whether the signals are close to 0 or close to 5V is judged 480,000 times a second. In other words, even there is noise within specific limits, it will not interfere with data transmissions. In broad terms, this way of comparing says that analog signals are a thousand times more likely to be affected by noise than digital signals. When this point is considered, the difficulty of the task involved in eliminating the effects of noise on analog signals becomes all too self-evident.

● **Effects exerted by ON/OFF of CD player displays on sound**

What led the author to understand the effects of noise on audio is the difference in the sound between when the CD player display is ON and when it is OFF. Frankly speaking, the sound is degraded when the display is lighted.



**Display of CD player which adversely affects the sound**

*(it can be turned off on players above a certain price bracket)*

A word of caution is in order here. This degrading is not evident with everything: It is evident only when listening to specific sources of sound and specific sections of that sound. Conditions such as these are often attached to this kind of discussion. To put it another way, the degrading is not perceptible under any other circumstances. However, once the way in which the sound is changed is perceived and the “degraded sound” is heard, it is difficult to ignore it.

For the purposes of this paper, the author played a CD, and examined whether the ON and OFF statuses of the display were reflected in the data. He played a CD (TD-CD02 entitled “Akiduki Densi Tsusho audio check CD”) containing minus infinity, -60 dB and -20 dB signals at 1 kHz, and he recorded the analog output signals using an MD deck equipped with a 20-bit A/D converter. After transferring the signals as digital data over an optical cable to his personal computer, he did a waveform analysis. He did not record a digital output because he was simulating actual CD playback.

At all three signal levels, no differences between the display ON and OFF statuses were in evidence. Even when the levels were compared by statistical processing, there were absolutely no differences in the figures. Be this as it may, the human ear can still pick

up the presence of very faint digital noise which is generated because of the display.

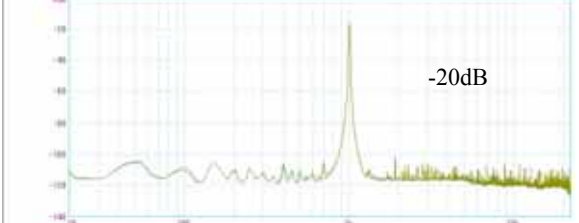
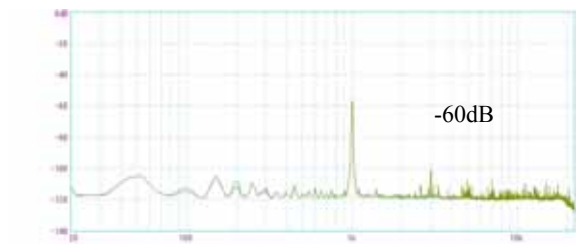
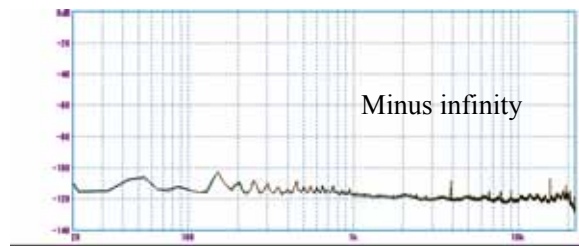

**Difference between when display of CD player is on and off**

Playback CD signals: Minus infinity, -60 dB, -20 dB (no differences whatsoever)

● **Our ears: a tool better than measuring instruments**

The fact that there were no differences in the data between when the CD player display was ON and when it was OFF was just as the author expected. To be sure, the human ear has an extremely high detection ability.

The constant-voltage power supply used for the diode rectification noise experiments was made in order to carry out hearing tests on the differences in the sound produced by the differences in the diodes used. The speakers for the personal computer used in this com-

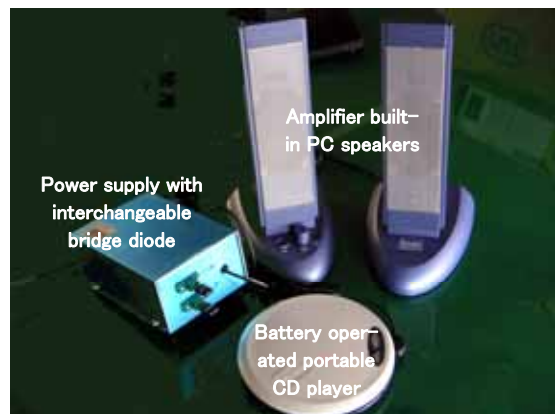

**Simple test-listening equipment for ascertaining differences in sound due to differences in diode**

bination of products were not special ones, and the same can be said of the CD player.

Even when the diode was changed, no changes in the constant-voltage power supply output of 12V were detectable. The power supply is operated with its cover closed so the magnetic flux leakage can obviously be ignored. Even with this simple arrangement of equipment, it was still possible to hear the difference in sound produced by the diodes. This, too, is an instance that ably demonstrates just what superior capabilities our ears have.

## ● Does the noise of electronic equipment affect the sound?

It was possible for the author to hear the difference in the sound between when the CD player display was ON and when it was OFF. The question is what about the differences in the sound when the air purifier, the largest noise source in the author's room, is ON and when it is OFF, and also what about these differences when the personal computer is ON and when it is OFF. To be perfectly honest, the answer to both these questions is that it is hard to say one way or another.

Some people talk about the effects of the noise generated by electronic equipment on the sound in terms of the "number of the sounds heard decreases" or "the spaces becomes smaller." These differences are very subtle, and the number of people who can actually identify them is no doubt extremely limited. For the majority of audiophiles, being overly concerned about noise may simply be a matter of needless worry. In fact, worrying too much about the sound can end up depriving the listeners of the very pleasure they would otherwise gain from listening to music.

Through his experiments on noise, the author became aware of the fact that there are so many electrical products whose noise cannot be controlled. Products such as the air purifier, personal computers and fan heater in his room can be turned off if the author wishes to do so when he listens to music. However, he cannot turn off at will the light fixture with its dimming function which is controlled by a thyristor in the adjoining room and which appears to emit a high level of noise. In addition, the low-frequency noise conducted along the power lines from sources outside the author's room would figure as being a relentless intrusion. If the author were to turn off all the electrical products in his room, switch off the lights and shut down the air conditioner or heater, he would be shivering in winter and perspiring profusely in summer. His room would also be full of cigarette smoke, creating an environment hardly conducive to the enjoyment of music. In order to eliminate the noise entering from sources outside his home, the author would have to walk around his house holding a noise checker and go around to all other homes where there are sources of noise to complain about them. There's no way the author can do this however fussy he may be about noise.

Even when there is noise in the environment, in many cases it is either imperceptible or unproblematic. At this point, the author would like to change his perspective from which to discuss the issue of noise. This is for the sake of marshalling some theoretical arguments to ensure his mental health.

## ● Products which are not susceptible to the effects of noise

*Products which are not susceptible to the effects of noise are ones which are fabricated based faithfully on to their electrical and other principles with no corners cut in the process.*

As the first example of reflecting these principles, the author compared the radiated noise between a parallel AC cable and twisted wire AC cable. In recent times, twisted wire cables have not been seen very much, but up to a generation ago they were used in electrical thermos flasks, heaters and electric "kotatsu" which consumed a lot of power.

The author detected and compared the radiated noise emanating from each of these cables using his AM radio.

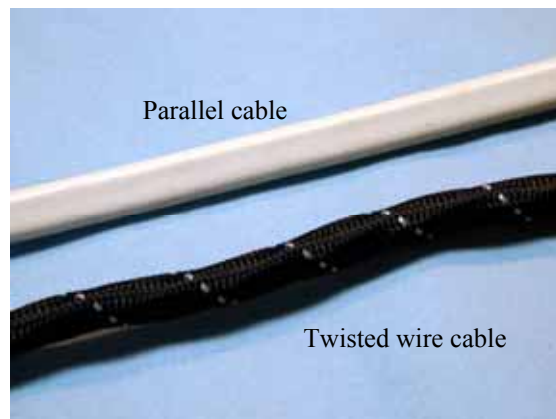

Parallel and twisted wire AC cables

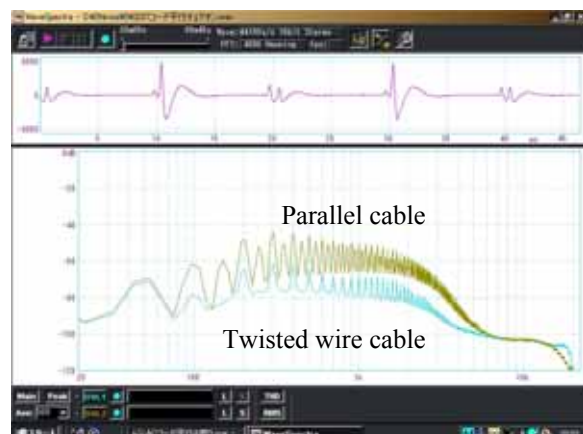

Radiated noise from parallel and twisted wire AC cables

The graph above shows that the twisted wire cable has a lower level of radiated noise. Twisting wires is well known as an elementary way of suppressing noise. Although power cables were used for the com-

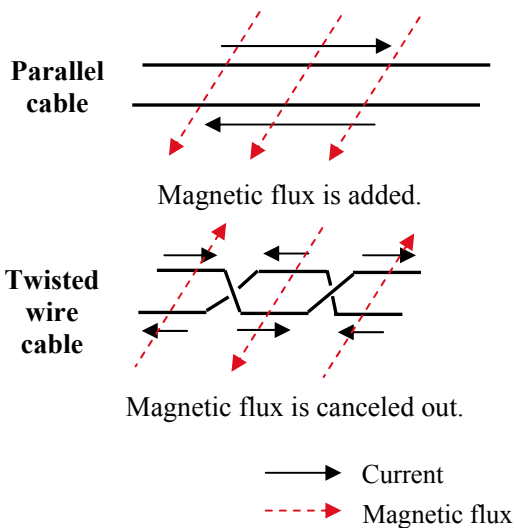

**The amount of electromagnetic induction noise generated by a twisted wire cable is less than that generated by a parallel cable.**

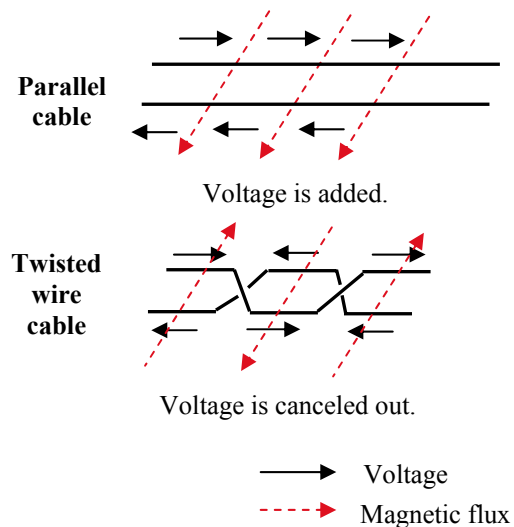

**The electromagnetic induction voltage is less in a twisted wire cable than in a parallel cable.**



**Power cable using a star quad cable (consisting of 4 twisted wires)**

parison, the same results would be yielded by signal cables as well. Twisted wires are less likely to become sources of noise, and they are not easily affected by noise, either. It is for this reason that twisted wires are sometimes used instead of shielded cables.

The study of electromagnetics helps us to understand the mechanism working behind noise. The two figures on the left can be used to explain why twisted wires are a better choice.

From this point on, the discussion will be limited to audio and to what steps can be taken to make it harder for the equipment to be affected by noise and, even when it is affected, how these effects can be made negligible.

Let us bring up again the basic measures which are commonly taken to counter noise in electronic products which include audio equipment.

- Selection of electrical, electronic components**
- A. Components**  
No noise output or received.
  - B. Filtering**  
On-board: Signal lines  
On-board: DC power supply lines  
AC power supply lines  
Harnesses, cables  
Circuit boards, wiring, chassis, cables
  - C. Patterning**  
Separation between power supply systems and signal systems  
Separation between digital and analog  
Thick, short and twisted
  - D. Grounding**  
1-point grounding  
Multi-point grounding
  - E. Shielding**  
Shielding of circuits, components  
Shielding of harnesses, cables  
Shielding of each function block

In addition, it is common in semiconductor amplifiers to use a differential amplifier to receive the input signals so as to ensure that the normal mode noise has no effect. The appropriate pattern design and personal computer power supplies are also effective ways to deal with noise.

When things are looked at in this way, as it is often pointed out, the audio equipment made by the established audio manufacturers faithfully reflects the basics of dealing with noise. However, if one were to take these measures oneself when setting about putting together an amplifier or other audio component on one's own, it would be much easier said than done. In this sense, remaining faithful to the principles requires both a sophisticated level of technical expertise and the ability to make the right evaluations. It is assumed that the top-end audio equipment made by the established audio manufacturers is not affected by the radiated noise from external sources. The rea-

son for this is that their chassis are built in such a way that they do not radiate noise externally. In a top-end unit, even the smallest cracks and gaps are filled with shielding material, and consideration is given to ensure that the “bonnet” does not electrically float up from the chassis. The fact that no noise emanates from an audio component means that it is hard for the component to be affected by external noise. Therefore, it is probably safe to say that the problem in audio equipment is the noise conducted from the power lines and the noise generated inside the component chassis themselves. The noise in this context consists of both conducted noise and radiated noise.

The author used the expression earlier “with no corners cut” for good reason. It seems that not cutting corners is more important in this day and age than one might think, and the author feels it is worth paying the higher prices tags for products which are made without cutting corners.

In this discussion, the author has primarily discussed the audio equipment of the established audio manufacturers, but if he were to discuss the kind of audio equipment that audiophiles may set about making themselves, it would be a slightly different story. It is quite difficult to create the shielding which will protect the equipment from radiated noise. The parts and materials that do-it-yourself audiophiles obtain are rather limited; neither would they be up to the task of handling the complexity of the work involved.

In the following, the author has put together some points which should be taken into consideration to protect audio equipment from the effects of noise.

### ● Keep the power of noise-generating products likely to affect audio equipment turned off whenever possible.

In the ordinary home environment, the electronic equipment with high power consumption levels and switching frequencies below 100 kHz represent the greatest concern in terms of noise. More specifically, the author has made a list below of the kinds of devices that audiophiles should be concerned about in terms of the noise conducted along AC power lines:

- Desktop computers
- TV sets, monitor displays, projectors
- Air conditioners, refrigerators, washing machines and other inverter home electrical appliances
- Inverter lighting fixtures
- Telephones, ISDN, ADSL

The author has listed “desktop computers” rather than “personal computers” because note PCs generally consume less power and generate less noise. As far as lighting fixtures are concerned, dimming functions that use the phase control of incandescent light bulbs cause more noise because of the principles involved. Some non-inverter fluorescent lights (the old fluorescent lights) generate unexpectedly high levels of noise. One may think that ceramic heaters and Nichrome wire heaters simply involve resistance, but

they actually generate quite a lot of noise as well. The author believes that this is because the AC power line voltage itself is distorted and it contains lots of harmonics.

### ● Remember that there are power supplies (noise sources) that “never sleep”!

The author was not aware that an air purifier is an electrical unit that never sleeps. “Never sleeping” applies to units that continue to draw power even when their power is turned off so long as they remain plugged into an electrical outlet. An AC adapter without a switch is a typical example of this. An air purifier generates ions, and for this reason a high-voltage power supply continues to run even when the power of the purifier is turned off. The author discovered this fact because power was being consumed--although its level was less than 1W--even when the power of his purifier was shut down. With desktop computers, the standby power continues to flow, consuming 3W to 4W even in the standby mode. An investigation into these units led the author to realize that air conditioners are also in the standby mode.

An AM radio is a useful tool to find out which electrical or electronic devices in the home are connected to the power sources which never sleep and continue to emit noise. In fact, it was with an AM radio that the author discovered that his air conditioner never sleeps. The cheapest kind of AM radio available for about a thousand yen is good enough for this job.

To counter the effects of the electrical devices that never sleep, either their AC plugs must be disconnected or separate switches must be provided so they can be turned off.

### ● DVD-Audio, SACD and AV equipment

The frequencies audible to the human ear are said to be in the 20 Hz to 20 kHz range. CDs playable up to a frequency of 20 kHz use 44.1 kHz sampling. The sampling frequencies for the new formats are:

- Max. 192 kHz for DVD-Audio
- 2.8224 MHz for SACD

When the sampling frequency is higher, the frequency band of the noise that must be considered extends into a higher range as well.

The frequencies of video signals are:

- NTSC color (ground-wave TV signals)
- 15.734264 kHz for the horizontal sync signals
- 59.94 Hz for the vertical sync signals
- 3.579545 MHz for the burst signals

Example of a display monitor

- 30 kHz to 117 kHz for the horizontal sync signals
- 50 to 160 Hz for the vertical sync signals
- Up to 136 MHz for the video band

As shown above, the frequencies involved in TV and monitor display operations extend to regions higher than the audio frequencies. If the effects of noise cause the synchronization to be lost, flickering will

result on the screen. If noise affects the video signals, color shift will occur.

It is easier to discern the effects of noise visually than aurally. For this reason, it can be said that the effects of the noise countermeasures will be more readily pinpointed in the visual than the aural. On the other hand, there are people who are able to hear the differences even at levels so subtle that they cannot be detected even by measuring instruments. Whereas significant visual changes can easily be spotted by almost everybody, it is sometimes difficult to know where the differences lie because there is so much information to be processed.

At this point, we should ask some questions so we can figure out what countermeasures can be taken to deal with the noise. Are regular CDs involved or CDs in one of the new formats? Is it genuine audio or is video also included? How discriminating is the sensitivity of the individuals involved?

●Audio equipment and noise filters

The first countermeasure that comes to mind is the use of noise filters for the electrical devices which are either generating harmful noise or which are suspected of generating this noise. As the author mentioned earlier, hardly any noise filters work effectively in frequencies as low as 100 kHz or below.

The serial-type filters used for personal computers are not only useless in combating noise for audio equipment but harmful as well. These filters hardly ever do a good job of filtering out noise at low frequencies. In addition, they are designed with no consideration given to the AC plugs and wire materials that have such a significant effect on sound.

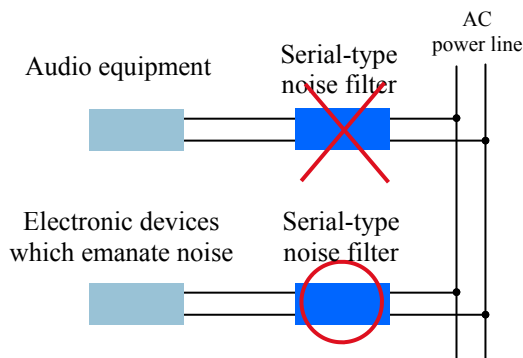

How to use serial-type noise filters with audio equipment

Actually, serial-type noise filters may be used by inserting them on the AC power lines of such devices as personal computers which are generating noise rather than the audio equipment itself. The reason for this is that noise filters work to prevent the noise from being emanated.

Since the supply current does not flow through parallel-type noise filters, these filters should not have an adverse effect on the sound. However, the advertised effects are not necessarily obtained by some of the

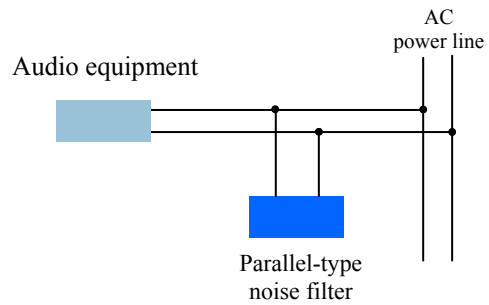

Parallel-type noise filter

filters despite their high price tags.

●Noise filters for low frequencies

Presented below are two examples of filters used for low frequencies.

#1: SUP-FH series made by Okaya Electric Industries



SUP-FH series noise filter

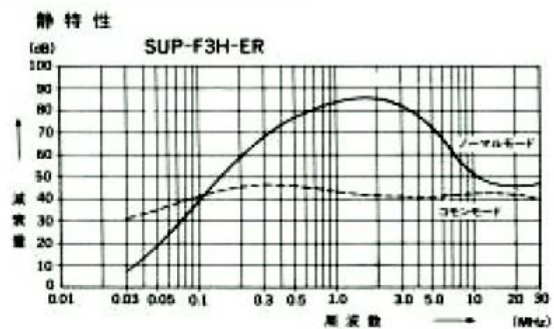

SUP-FH series noise filters

This takes the format of an AC inlet filter. Compared with the filter made by TDK Corporation mentioned earlier, it is bigger so that it can provide attenuation characteristics covering the lower frequencies.

#2: LNG-5A made by Sanritz

This comes in a format that closely resembles the most common table tap equipped with noise filter. It is easier to use because it does not have to be grounded. (Available for 8,900 yen from the Radio Center in the Akihabara district of Tokyo; TEL: <03> 3251-0938)

These two filters claim to provide attenuation characteristics below 100 kHz, and they may be effectively used to suppress noise for AV (Audio Visual) equipment. However, they are probably inadequate for suppressing noise in genuine audio equipment.



LNF-5A by Sanritz

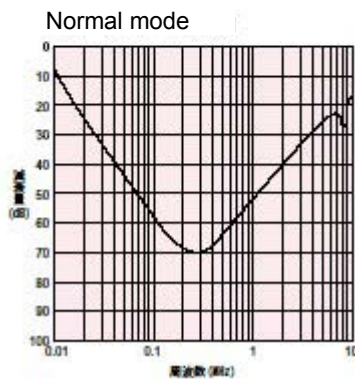
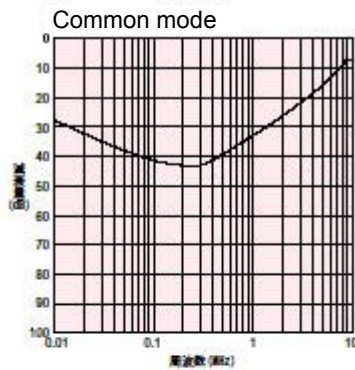

Characteristics of LNF-5A

Power cables for audio equipment that appear to incorporate filters are available on the marketplace. They are extremely costly, and it is quite possible that they will turn out to be of no use in combating noise depending on the wiring of the house and the equipment concerned.



MIT Z-cord II

## ●Noise-suppressing (noise-filtering) transformers

As can be seen from the results of measuring the noise carried along AC power lines, even power transformers allow noise up to 20 kHz to pass through. This means that these transformers cannot be expected to serve as noise filters to suppress low-frequency noise. In contrast, noise-filtering transformers do not allow noise with high frequencies to pass through.



Noise-filtering transformer by NF Corporation

The transformers effectively filter both normal mode and common mode noise, and they have dramatically superior attenuation characteristics in the low-frequency range than the LC filters that the author mentioned earlier.

The zero noise transformer made by Union Denki has the characteristics on the previous page. (<http://www.uniondk.co.jp/noizu.html>)

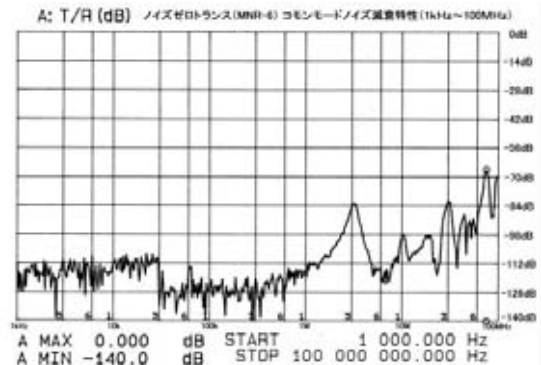
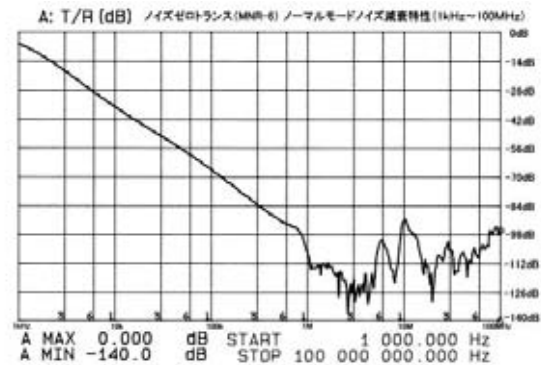

Characteristics of zero noise transformer made by Union Denki

Unlike LC filters, the transformer featured here also does not need a grounding wire, and it has a low leakage current. Furthermore, its filtering effect is unlikely to be affected by AC power line impedance: This means no series resistance and no increase in noise.

The biggest problem with these kinds of transformer is that they tend to be bulky and heavy. It is quite a struggle to carry home a transformer with a large capacity. Incidentally, the prices for the transformers made by NF Corporation are as follows:

- 74,800 yen for the NT-500C, 500VA
- 117,800 yen for the NT-1000C, 1000VA

These transformers are used for the kind of testing, measuring and control devices that are extremely sensitive to noise. However, the fact that they generate heat and droning sounds hardly makes them suitable for home-use audio equipment.

There are only a few products available on the market for audio equipment, and they come with high price tags. As such, they are not worth considering. On the other hand, there is a good chance that products for audio applications that make full use of new materials will come out in the future.

Some transformers come with shielding between their primary and secondary windings in order to prevent high frequencies from passing through. Although they are not classified as noise-suppressing transformers, they are used for this purpose and, as such, they could be described as a type of noise-suppressing transformer. However, in order to avoid any accompanying increase in loss, their filtering characteristics do not reach 50/60 Hz. This kind of transformer is used in some audio equipment.

●AC regulated power supplies

Even if it is true that noise-suppressing transformers are the most effective in filtering out noise in the low frequencies, they are not effective for the low-order harmonics which are carried in from the AC power lines. If this is the case so the logic goes, maybe just distortion-free sine waves should be created. This is the thinking behind the AC regulated power supplies which are equipped with the ability to output stable AC voltages. Two systems are used in the AC regulated power supplies which are sold on the market-place.

With one system, the AC output is stabilized by adding or subtracting the difference in the input AC voltage from the distortion-free sine waves used as a reference.

As can be seen from the output voltage spectrum diagram, this system significantly reduces the harmonic components using the input voltage ratio. The difference is compensated for by this system so the loss is minimal, and it is easy to make power supplies with a high output in compact dimensions.



Accuphase PS-510 (for audio applications)

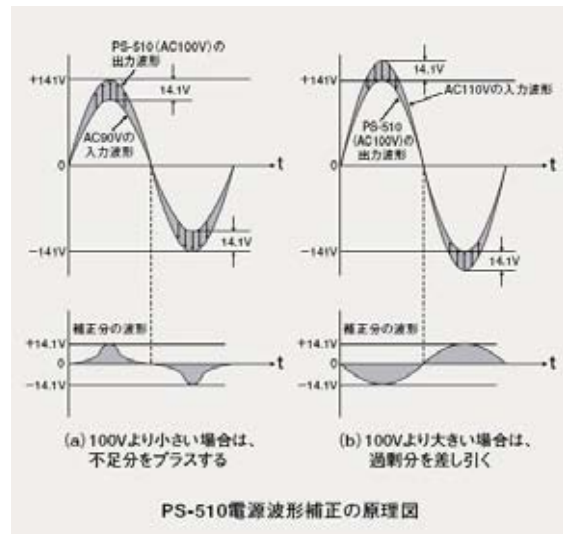

Principle of waveform shaping featured by PS-510 (source: product catalog)

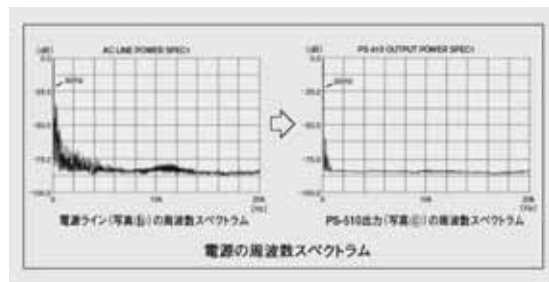

Reduction in harmonics by PS-510 (source: product catalog)

The other system consists in amplifying the sine wave oscillator output using an amplifier. As a result, since the loss is high, the power supplies that use this system are suitable for comparatively low outputs. It is relatively easy to change their frequency and output voltage. For example, by means of switches the frequency can be switched to 50 Hz, 60 Hz or 400 Hz, and the voltage to AC 100V or AC 200V. This type of AC regulated power supply has been employed for a long time in the measuring and control fields. AC regulated power supplies were not created for the

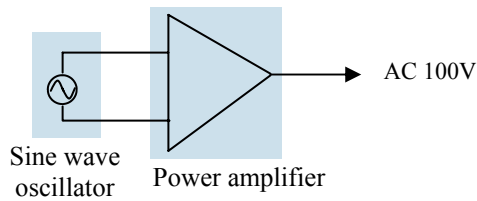

**AC regulated power supply of the type that amplifies the sine waves**

specific purpose of attenuating noise, but they can be used to provide virtually ideal noise countermeasures. Although they are referred to as power supplies, in actual fact they are power amplifiers. As such, unless they are designed to be used in audio applications, it still may not be possible to obtain a good sound.

**●Connecting to earth-ground?**

Quite a few people apparently believe that connecting equipment-ground to earth-ground will reduce noise. In reality, connecting to earth-ground has the opposite effect: It simply increases the noise in many cases. This is because the wire leading from earth-ground to the connection-to-ground point acts an antenna and picks up noise.



The cell phone is a good example of an electronic device that operates in a noisy environment. For a dialog to take place, it must be able to send out high-level voice signals while at the same time receiving faint signals. No earth-ground lines are involved, and cell phones are designed so that the effects of noise can be avoided without their being connected to earth-ground.

In airplanes, any malfunctioning of their electronic equipment would make it impossible for them to fly safely. Here, too, precision electronic equipment is seen functioning without a connection to earth-ground.

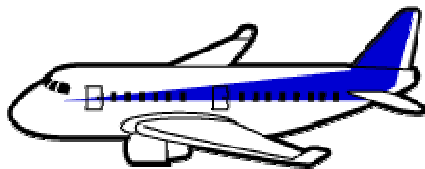

**Cell phones and airplanes are not connected to earth-ground.**

As can be seen from the above examples of cell phones and airplanes, connection to earth-ground is not the solution to all problems and, besides, it is not actually always necessary. On the other hand, connection to earth-ground is absolutely essential for every high-voltage power equipment in order to prevent electric shocks.

The author has used the phrase “earth-ground” to establish a differentiation from “signal-ground.” Signal-ground is the voltage reference point for signal processing. The earth is where the potential is at its most stable, and it is considered something that serves as the ideal ground. However, a ground wire may serve as an antenna, resulting in increased noise, and unexpectedly high currents may flow through a ground wire to increase the potential at the ground terminal. Therefore, the ground terminal does not necessarily represent the potential of the earth.

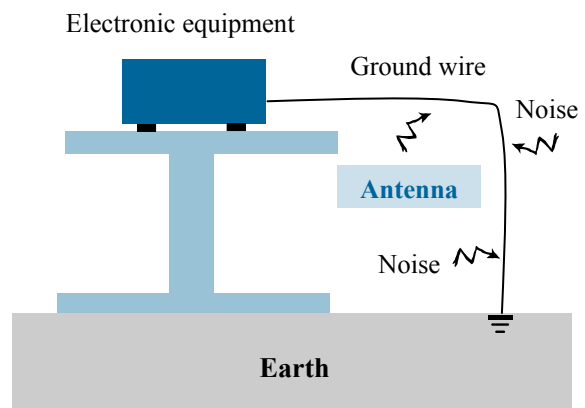

**The ground wire acts as an antenna and has the opposite effect of increasing the noise.**

With a ground wire acting an antenna, let us now calculate what kind of frequency each meter of that wire is equivalent to. The speed of light in a vacuum is  $3 \times 10^8$ , and the frequency can be obtained by dividing this by one-fourth of the length of the antenna. The result of this calculation is a frequency of 75 MHz. If we assume that the ground wire can act as an antenna even with a frequency which is a tenth or a hundredth of this, it appears that the wire does not have a very positive effect. If the wire is 10 meters long, for instance, it is likely to affect the frequencies below 100 kHz as well.

In short, grounding is essential when signals are handled. However, it is not necessary to make its potential the same as the potential of the earth. The fuselage of an airplane, the hull of a ship and the steel frame of a building all serve as an excellent signal-ground. Electronic equipment which is not connected to ground uses its chassis or frame as the signal-ground. Nowadays, it is more common not to provide connections to earth-ground for signals and, for this reason, electronic equipments are designed on this premise. Audio equipments are no exception to this, either.

People often say that connecting an audio equipment that handles very faint analog signals to an earth-ground has resulted in some degradation of their sound.

●Impulse noise

Typical impulse noise is generated with lightning surges or when high current levels are turned on and off. So far, the author has looked at the kind of noise that occurs continuously, but impulse noise is characterized either by its occurrence on a one-off basis or by a slow period but a high peak value. Impulse noise sounds like popping, it is irritating and, in a worst case scenario, it can destroy the electronic equipment. Noise filters incorporated into table taps are effective in countering this kind of noise.

Most noise filters which claim to ensure protection from lightning surges incorporate varistors. Varistors inhibit surge voltages by utilizing their properties that cause the resistance to be reduced at a certain voltage level or above. These filters do not provide fail-safe protection against all kinds of lightning surges, but since there are some easy-to-use types, it is true enough that using them can give some peace of mind. Realistically speaking, however, it is not possible to obtain these kinds of filters for audio applications. As such, the author recommends using such filters as parallel filters by plugging them into empty electrical outlets.

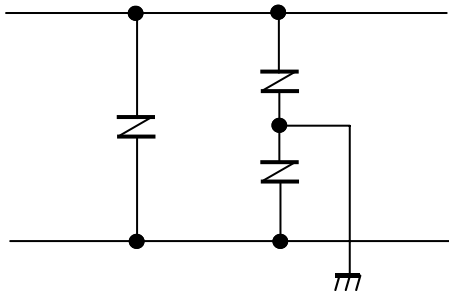

Lightning surge protection using varistor

●Effects of power supplies

The author mentioned earlier that care must be taken when using serial-type power supply filters and AC regulated power supplies. This is because time and time again he experienced that they have a significant effect on the sound from AC outlets, plugs and cables which are typical serial elements in power supply systems.

The photo shows an AC plug for audio applications: Its design was based on the AC plugs used for medical applications. The applicable Japanese Industrial



AC plug for audio applications based on medical uses

Standards stipulate the contact resistance, temperature rise, mating retention force, voltage withstanding and resistance to heat, impact strength, insulation and other characteristics of the AC plugs used for medical applications. By inserting one of these plugs into an outlet, it can be experienced just how securely it can be plugged in. The author had heard that using these plugs would improve the sound, and he replaced his AC outlets and plugs with ones designed for medical equipment just to see if they would make a difference. He was truly impressed by the difference. Since then, similar outlets and plugs for audio applications have become available on the market. All kinds of products designed to improve the sound are available, but the difference that the AC plugs and outlets makes is most impressive. One of the reasons why the author brought up the subject of the noise from plugs and outlets is that if a person cannot tell the difference that they make, then most probably he or she cannot tell what effect of the faintest noise may have on the sound which is what the author is discussing in this paper.

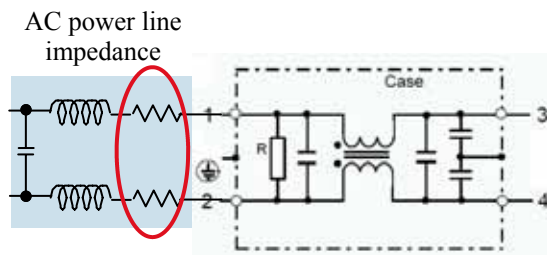

Resistance of power supply system affects the frequency characteristics.

It is believed that the AC plugs and outlets affect the sound because of their resistance. As can be seen from the figure, the frequency characteristics as a filter are affected by the resistance inside the power supply system. The extent of this effect obviously depends on the length of the indoor wiring and the diameter of the wire materials used.

●EMC on audiophiles in place of a post-script

The most important concern regarding audio should be the EMC on audiophiles like you. Extraneous noise is an issue which we come across in the mass media and in commercialism. But it appears that there is generally no outcry against noise. The only way to counter such noise is to check out our environment and establish our own standards. At the same time, it is also important to enjoy the music rather than the sounds heard.

The author recently went to a recital given by an amateur choral group. The group's last piece, Handel's Messiah, was really worth listening to, but the sound of the shorter pieces at the beginning felt muddled, and the author was reminded of the concept of cross

modulation distortion. The very sources of the sound may contain sound which comes across as distorted. Microphones and other recording devices may also contain distortion. What this means is that the sources of music CDs and other media thus recorded may already contain their own distortion. Since we cannot tell from the playback sound what kind of sound was originally recorded, any attempt to discuss the quality of the sound is bound to have definite limitations.

The author decided not to include external noise in his paper. It is sufficient to note that he does not take what older authorities have to say about this subject as the known truth, and although he would buy a 3,000 yen AC plug, he has no interest in making an investment in power cables that cost 50,000 yen or 100,000 yen. If this kind of outlay is to be invested, it would be better to increase the power capacity delivered by the power company and use wires with larger diameters in the house. In addition, it should be pointed out that improving the sound is different from changing the sound. One can do all kinds of things to change the sound, but it appears that when significant changes are made, they will often pave the way for improvements in some areas but not in others.

The author conducted some experiments as follows to see whether he could hear the difference in the level of noise between when his CD player display was on and when it was off. He played a section lasting 5 seconds or so on a specific CD over and over. He switched off the player's display using a remote control while sitting at a position where he could not see the display. The switching was performed between four positions including the dimmed display. In other words, these were blind tests. The first time around, he could hear the difference when the display was off. He tried for the second time, and he could hear it again. However, at this point he stopped because he was not confident that he could tell when the display was off the third time around.

The difference was actually so subtle that having the display on did not detract from the author's enjoyment of the music at all, and it was not really discernible except during the section of the CD in question.

It is possible to get a good idea of the sources and levels of noise by walking around your living quarters while carrying an inexpensive AM radio. After turning off all electronic equipment wherever this is possible, turn one piece of equipment on and see if the sound from the radio is affected. The ability to discern the effect depends on the individual's level of sensitivity (capabilities).

Once one begins to become aware of something, be it noise or something else, the tendency is to notice it more and more. This may end up as an obsession with finding noise.

It is really interesting to conduct experiments on noise in many different ways. Noise may be found where it is least expected. It is fun to do all this one-

self, gather the data, and figure out where the noise originates. By and large, doing this is not particularly costly.

It must be noted, however, that even people who are experienced in these matters must still exercise due caution when it comes to doing anything that involves the power lines. Needless to say, it would be most unfortunate if, while trying to minimize noise, a person should jeopardize his life and, worst yet, lose it.

There is no denying that the digital revolution continues to make steady inroads into audio equipment and its sources. Noise is all around us in our daily lives. The C-2000 made by Accuphase Laboratory Inc. that the author currently uses as his preamplifier incorporates a microcomputer. Even in such an environment, noise can be comfortably minimized by taking care of certain key factors, and after this is done, there is no need to be overly concerned about it. This are the author's conclusions.

The author said earlier that he does not take what the older critics say about noise as the obvious truth. To be sure, there is no reason why we should take anybody else's word for anything, and the author hopes that the reader has read this paper with some measure of skepticism.

Finally, an illustration of the noise countermeasures for audio equipment is provided as a conclusion to this paper.

### References:

Basics of Noise Countermeasures, TDK Corporation  
[http://www.tdk.co.jp/tjpbcd01/bcd27\\_30.pdf](http://www.tdk.co.jp/tjpbcd01/bcd27_30.pdf)

Electromagnetic Noise Countermeasure Technology and Products, TDK Corporation  
[http://www.suzuden.co.jp/gijyutu/pdf/pdf32\\_02.pdf](http://www.suzuden.co.jp/gijyutu/pdf/pdf32_02.pdf)

## Noise Countermeasures for Audio

\*Below are some tips on the noise countermeasures which can be taken without having to drastically alter the living environment at home or the AC power lines and which are not too extreme. The author hopes that they will give the reader some ideas.

